

Colour Resemblances 1.3

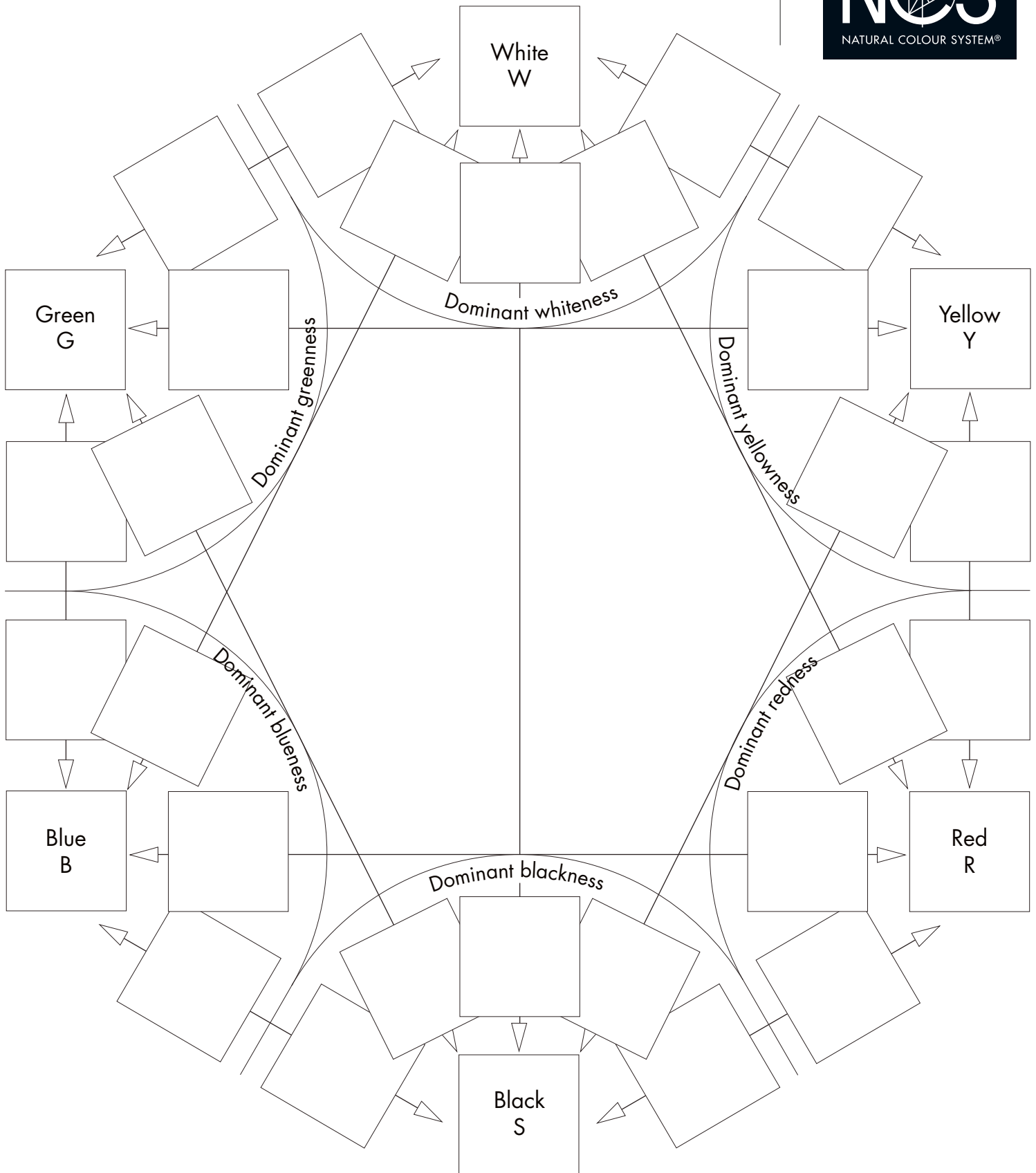

Arrange the colour samples into six groups according to the attribute that is the most dominant (the main attribute): whiteness, blackness, yellowness, redness, blueness and greenness. In each group there is one colour

sample that is 'pure', e.g. pure white (W) or pure red (R) (elementary colours). Mount these in their allocated places. All other colours in a group are related to some of the other elementary colours (sub-attributes). Mount these colours so

as to build the first step in a scale towards the elementary colour to which it is related (according to the arrows). E.g. mount the yellow colour that is reddish among the yellow colours in the square with an arrow pointing towards red.

Colour circle 2.1

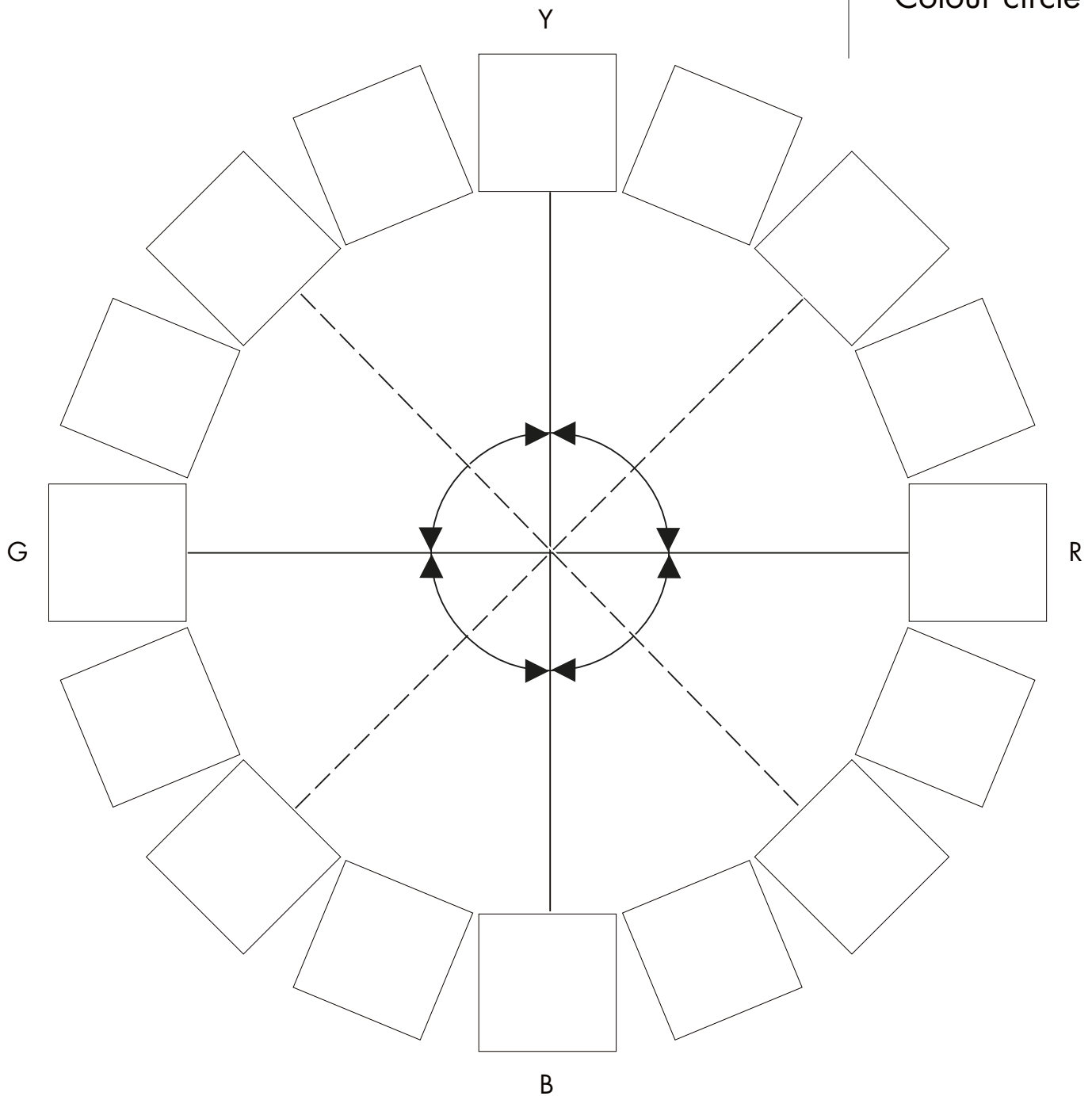

Arrange the samples in three groups according to main attributes: whiteness, blackness and chromaticness. Begin with the most chromatic colours and pick out:

- the yellow colour (Y) that has neither greenness nor redness
- the red colour (R) that has neither yellowness nor greenness

- the blue colour (B) that has neither redness nor greenness

- the green colour (G) that has neither blueness nor yellowness.

Mount these as indicated in the circle.

The other colours in the chromatic group should then be mounted so as to make scales between these four colours. The colours that resemble

both red and yellow should be mounted between these two, the one most like yellow next to the yellow and so on, so that redness increases towards red, while yellowness decreases.

The two other groups where whiteness is the main attribute in one and blackness is the main attribute in the other, should be arranged in the same way.

Colour triangle 2.2

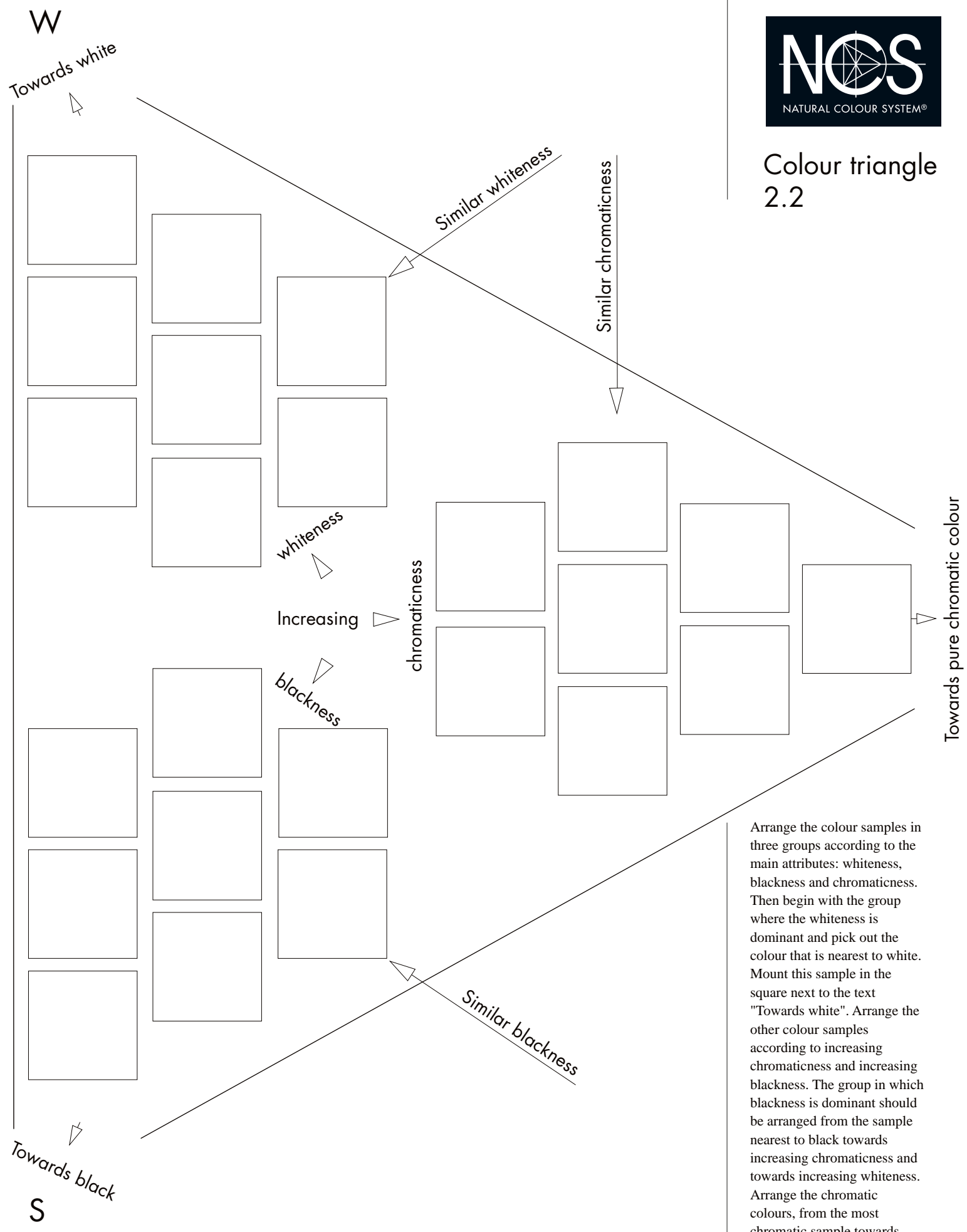

Arrange the colour samples in three groups according to the main attributes: whiteness, blackness and chromaticness. Then begin with the group where the whiteness is dominant and pick out the colour that is nearest to white. Mount this sample in the square next to the text "Towards white". Arrange the other colour samples according to increasing chromaticness and increasing blackness. The group in which blackness is dominant should be arranged from the sample nearest to black towards increasing chromaticness and towards increasing whiteness. Arrange the chromatic colours, from the most chromatic sample towards increasing whiteness and increasing blackness.

Colour triangle 2.2

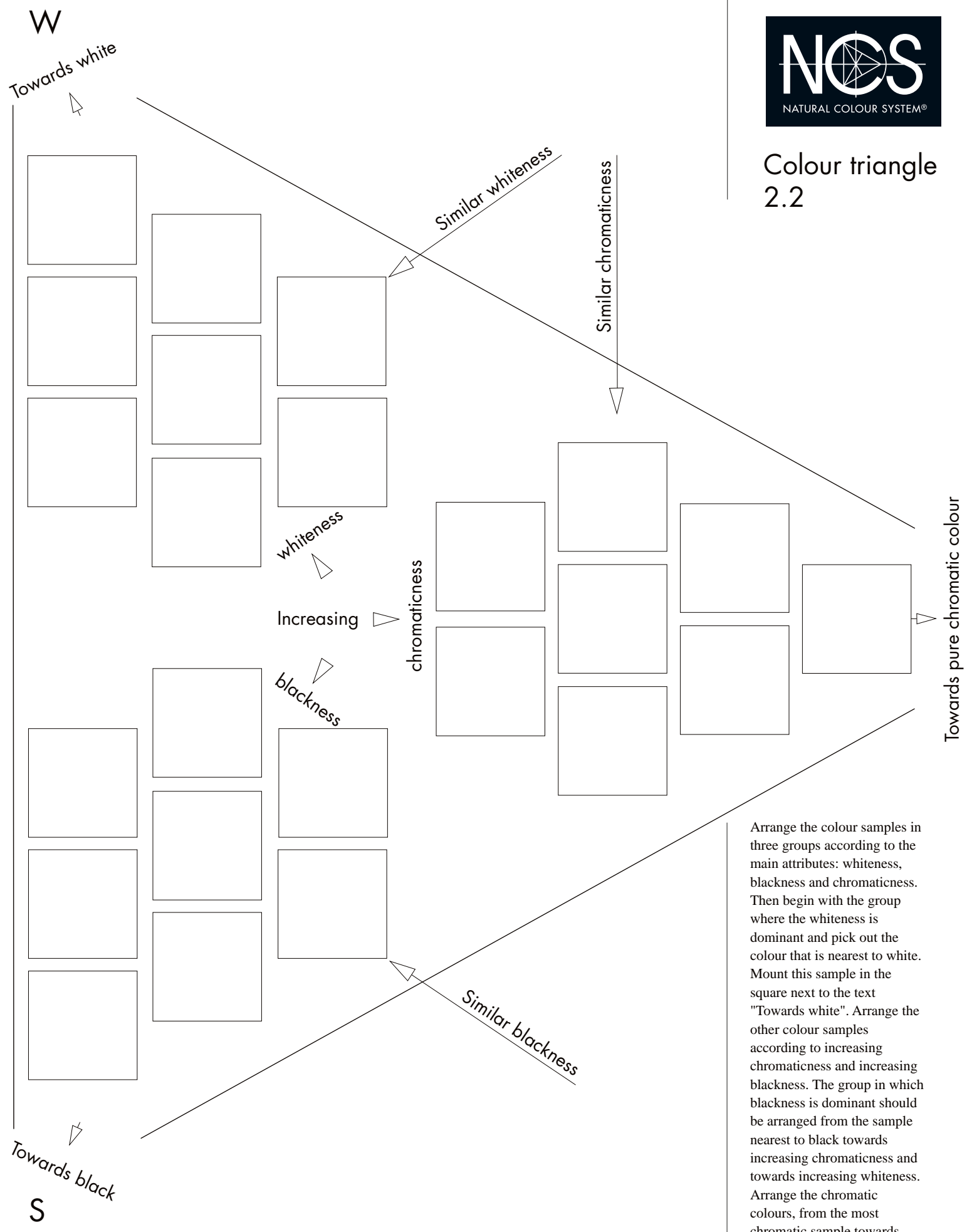

Arrange the colour samples in three groups according to the main attributes: whiteness, blackness and chromaticness. Then begin with the group where the whiteness is dominant and pick out the colour that is nearest to white. Mount this sample in the square next to the text "Towards white". Arrange the other colour samples according to increasing chromaticness and increasing blackness. The group in which blackness is dominant should be arranged from the sample nearest to black towards increasing chromaticness and towards increasing whiteness. Arrange the chromatic colours, from the most chromatic sample towards increasing whiteness and increasing blackness.

Colour triangle 2.2

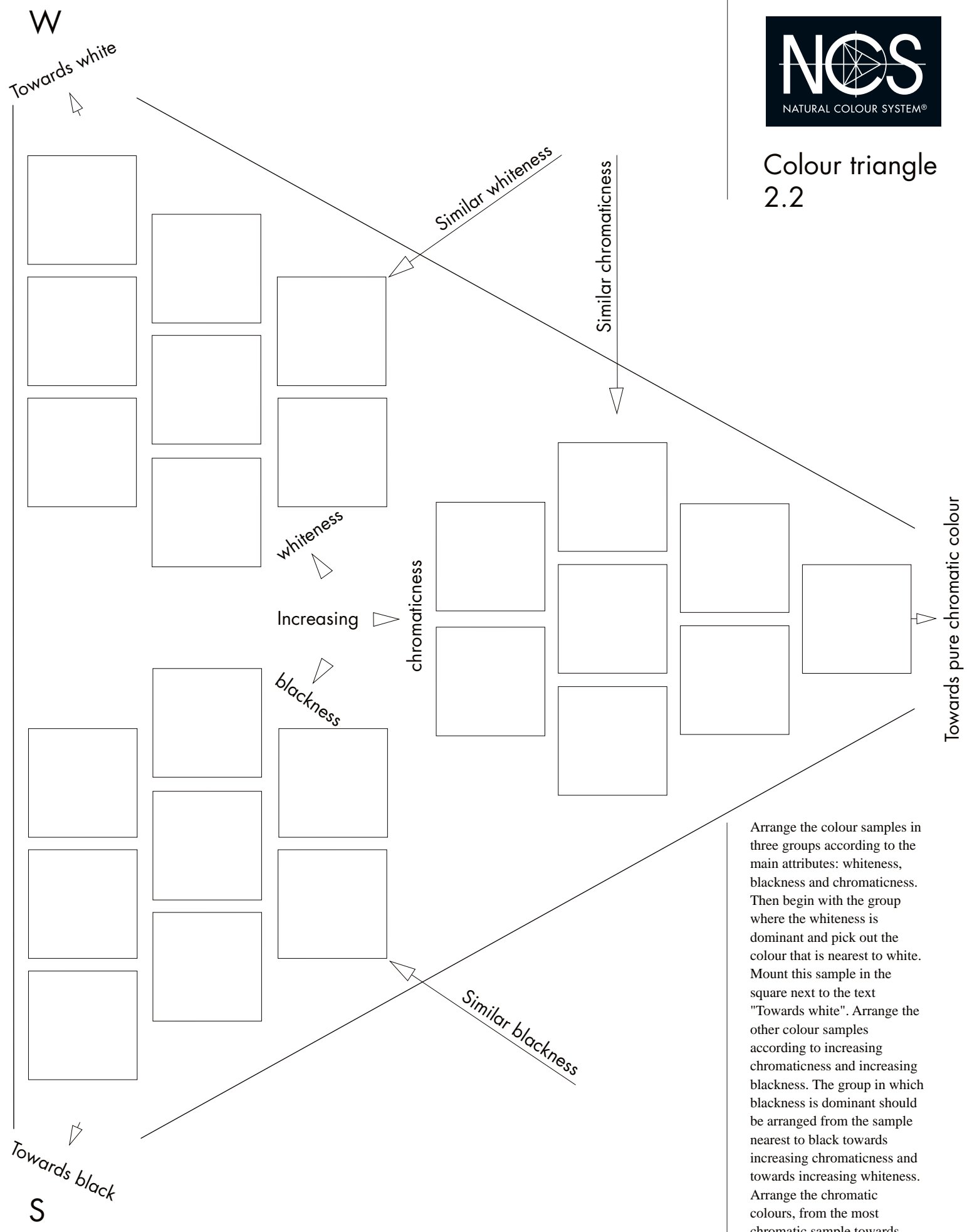

Arrange the colour samples in three groups according to the main attributes: whiteness, blackness and chromaticness. Then begin with the group where the whiteness is dominant and pick out the colour that is nearest to white. Mount this sample in the square next to the text "Towards white". Arrange the other colour samples according to increasing chromaticness and increasing blackness. The group in which blackness is dominant should be arranged from the sample nearest to black towards increasing chromaticness and towards increasing whiteness. Arrange the chromatic colours, from the most chromatic sample towards increasing whiteness and increasing blackness.

Colour triangle 2.2

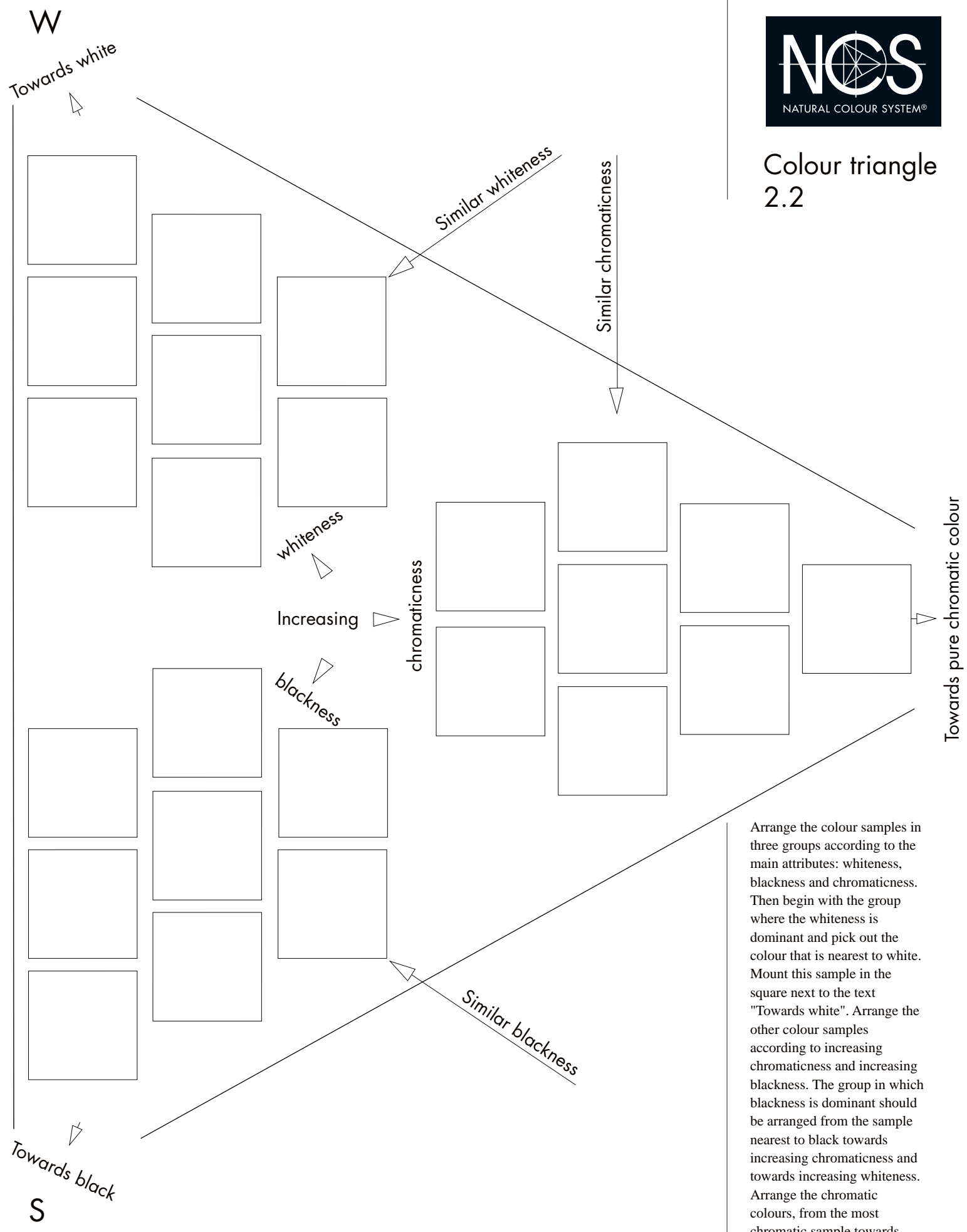

Arrange the colour samples in three groups according to the main attributes: whiteness, blackness and chromaticness. Then begin with the group where the whiteness is dominant and pick out the colour that is nearest to white. Mount this sample in the square next to the text "Towards white". Arrange the other colour samples according to increasing chromaticness and increasing blackness. The group in which blackness is dominant should be arranged from the sample nearest to black towards increasing chromaticness and towards increasing whiteness. Arrange the chromatic colours, from the most chromatic sample towards increasing whiteness and increasing blackness.

Colour analysis 2.3:1

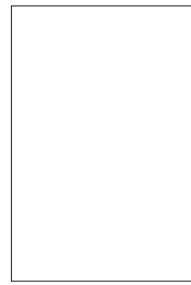
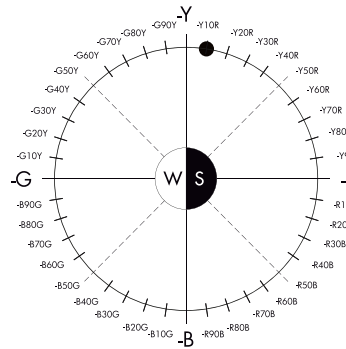
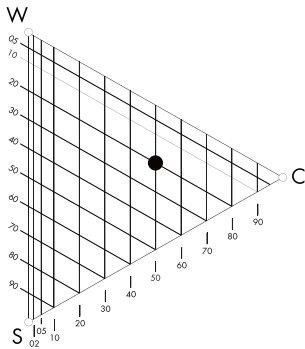

NCS

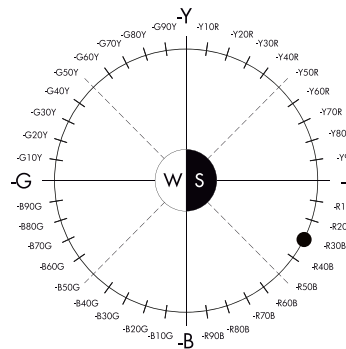
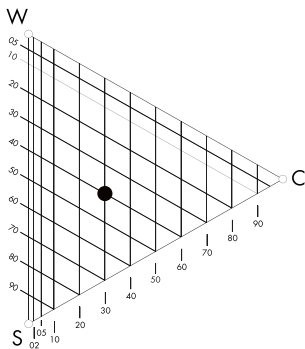

NCS

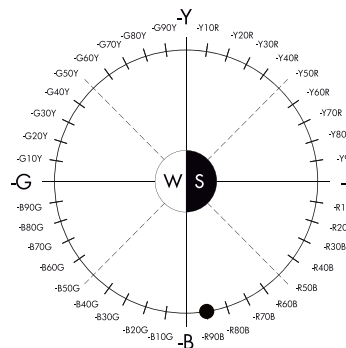
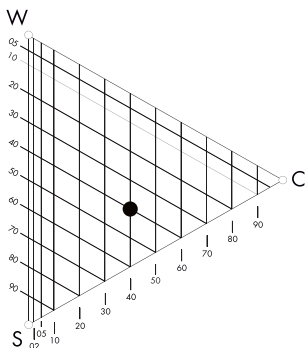

NCS

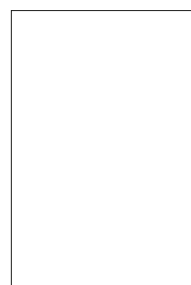
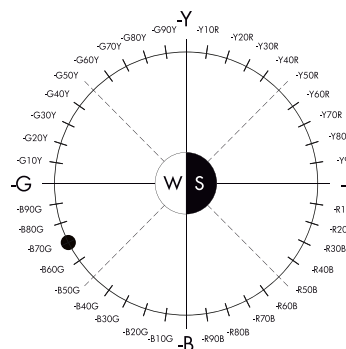
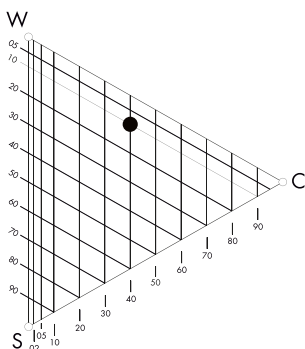

NCS

An NCS determination of colours through a visual interpolation. The four colour samples are not from the NCS ATLAS. Find the closest NCS colour samples in an NCS ATLAS or in any other complete NCS colour sample collection. Try to determine the exact NCS notation of each colour sample by interpolating the colour samples. Indicate also the colours by placing dots in the colour triangle and the colour circle. You will find the exact NCS notations for each of the colour samples on the label inside the plastic bag.

Colour analysis 2.3:2

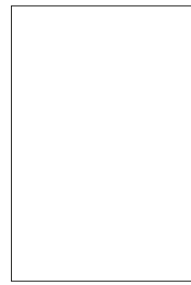
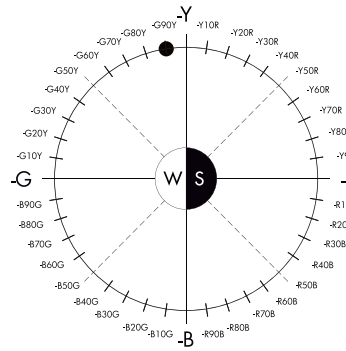
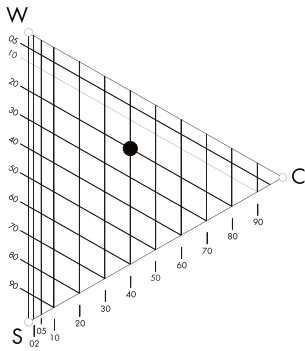

NCS

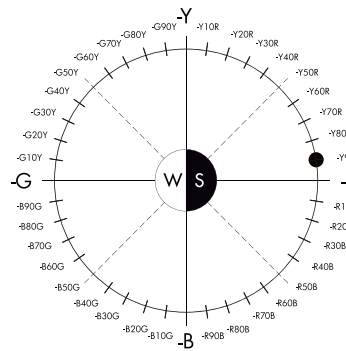
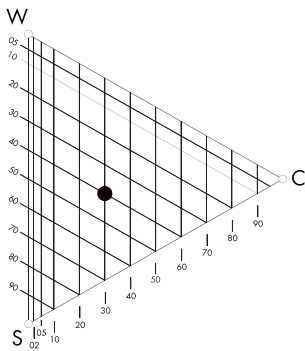

NCS

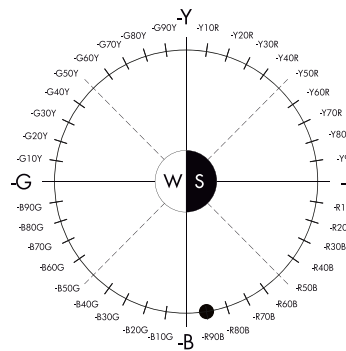
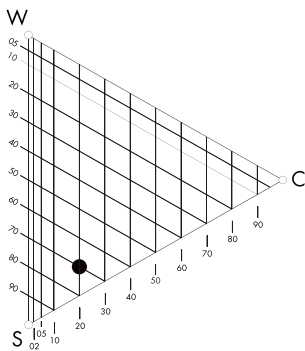

NCS

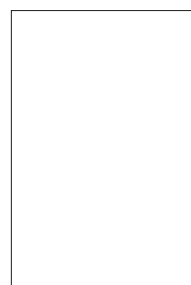
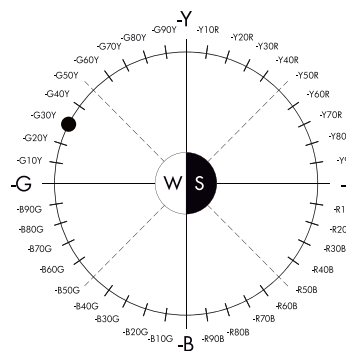
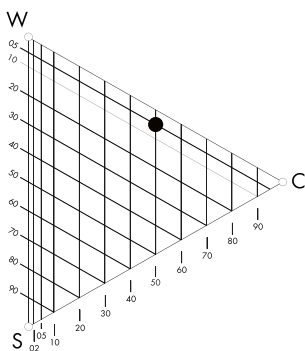

NCS

An NCS determination of colours through a visual interpolation. The four colour samples are not from the NCS ATLAS. Find the closest NCS colour samples in an NCS ATLAS or in any other complete NCS colour sample collection. Try to determine the exact NCS notation of each colour sample by interpolating the colour samples. Indicate also the colours by placing dots in the colour triangle and the colour circle. You will find the exact NCS notations for each of the colour samples on the label inside the plastic bag.



Colour analysis 2.3:3

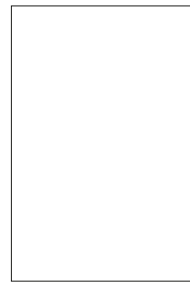
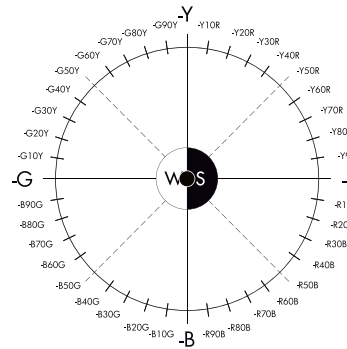
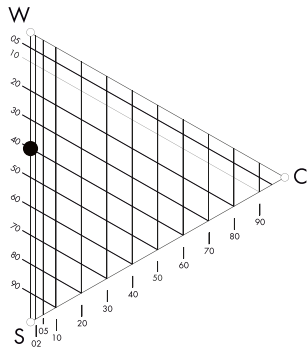

NCS

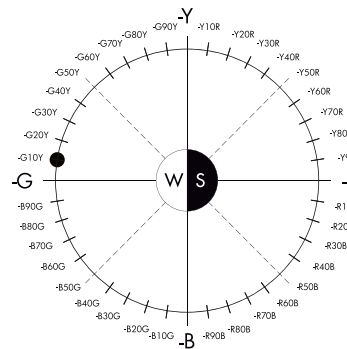
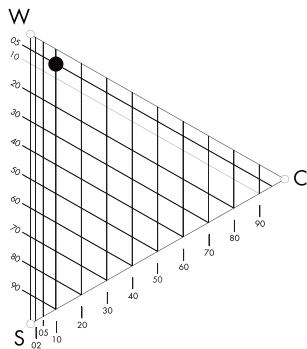

NCS

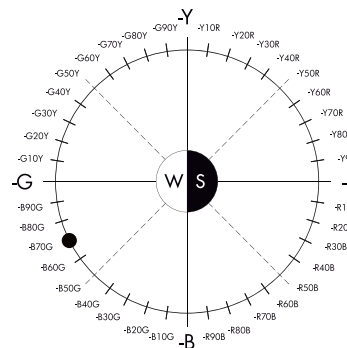
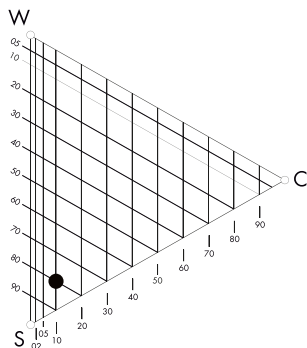

NCS

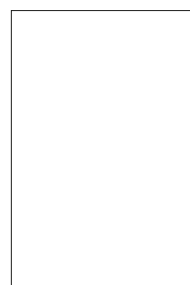
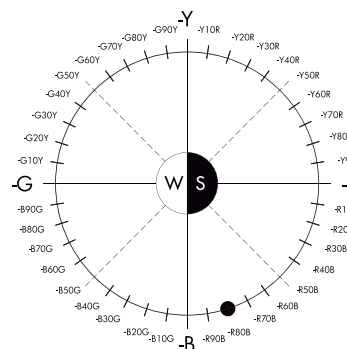
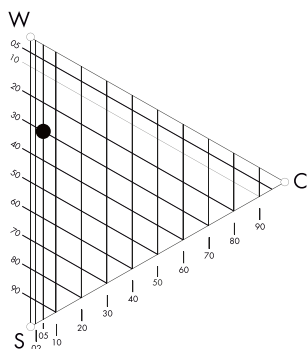

NCS

An NCS determination of colours through a visual interpolation. The four colour samples are not from the NCS ATLAS. Find the closest NCS colour samples in an NCS ATLAS or in any other complete NCS colour sample collection. Try to determine the exact NCS notation of each colour sample by interpolating the colour samples. Indicate also the colours by placing dots in the colour triangle and the colour circle. You will find the exact NCS notations for each of the colour samples on the label inside the plastic bag.



Colour analysis 2.3:4

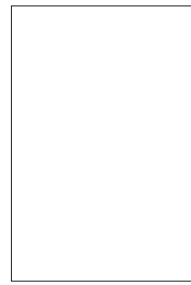
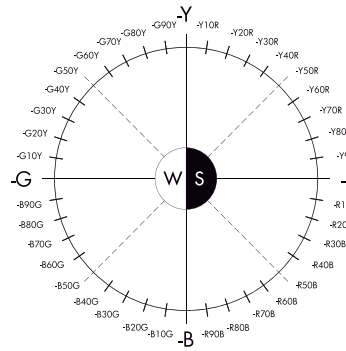
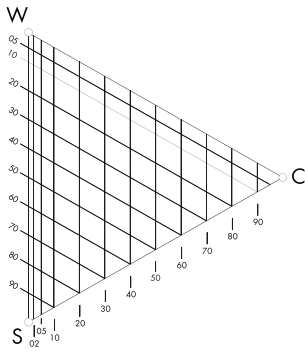

NCS

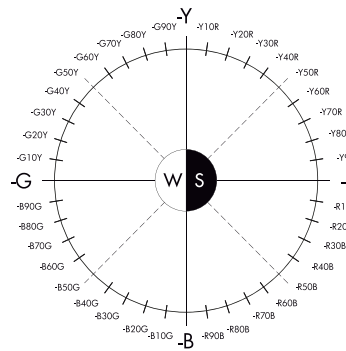
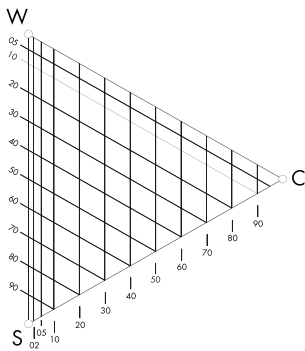

NCS

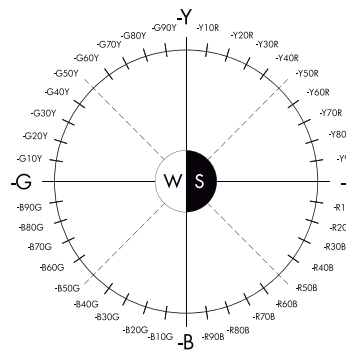
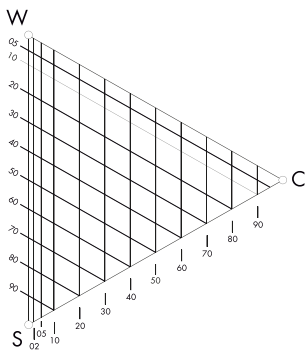

NCS

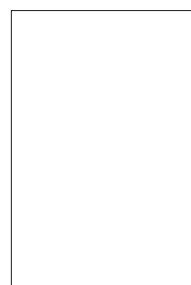
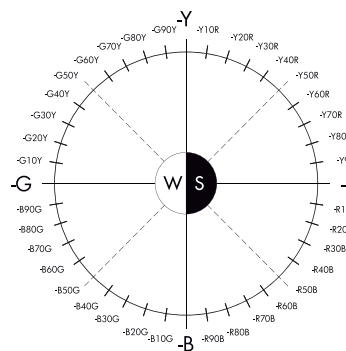
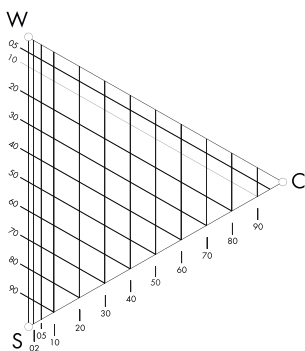

NCS

An NCS determination of colours through a visual interpolation. The four colour samples are not from the NCS ATLAS. Find the closest NCS colour samples in an NCS ATLAS or in any other complete NCS colour sample collection. Try to determine the exact NCS notation of each colour sample by interpolating the colour samples. Indicate also the colours by placing dots in the colour triangle and the colour circle. You will find the exact NCS notations for each of the colour samples on the label inside the plastic bag.

Colour areas 3.1

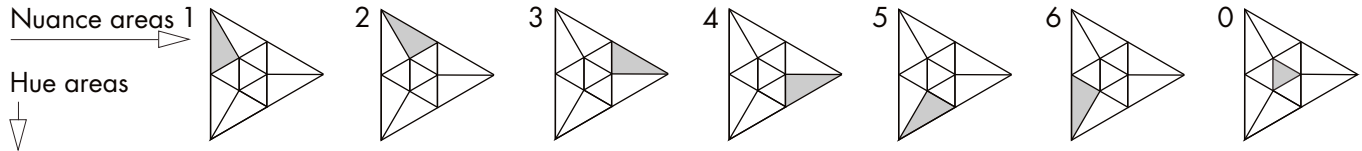

- 1. G50Y-Y
- 2. Y-Y50R
- 3. Y50R-R
- 4. R-R50B
- 5. R50B-B
- 6. B-B50G
- 7. B50G-G
- 8. G-G50Y

Colours may be arranged according to main and subordinate attributes in different colour areas, partly in the areas of different nuances illustrated in the colour triangle, and partly in the areas of different hues illustrated in the colour circle. In this schedule you see the 'world of colour' divided into 56 characteristic areas. Arrange the colour samples into four groups according to the main attributes: a) whiteness, b) chromaticness, c) blackness, d) no obvious

main attribute. The colours with whiteness as main attribute should be placed in nuance area no 1 or no 2 depending on the dominating sub-attribute, blackness in nuance no 1 and chromaticness in nuance no 2. The sample with chromaticness as main attribute should be placed in nuance area no 3 or no 4 depending on the dominating sub-attribute, whiteness or blackness. The sample with blackness as main attribute should be placed in nuance area no 5 or no 6

depending on the dominating sub-attribute, chromaticness or whiteness. The colour samples that have no obvious main attribute should be placed in nuance area no 0. In each nuance area there are now eight colour samples that should be arranged in the hue areas: 1) colours with greenish yellow hue, 2) colours with reddish yellow hue, etc.

Hue Similarity 4.1

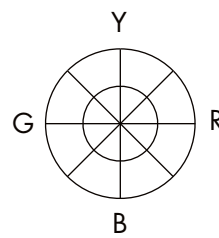
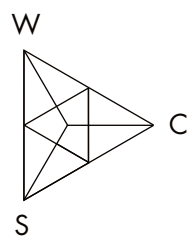
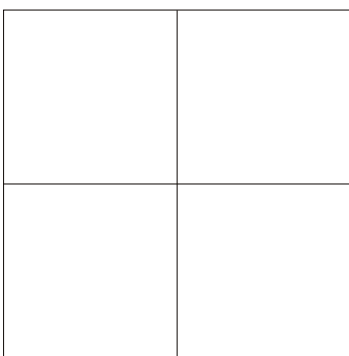
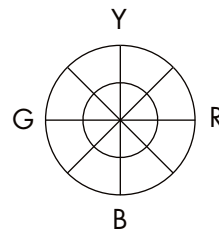
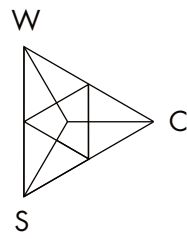
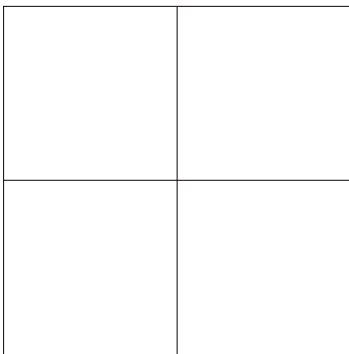
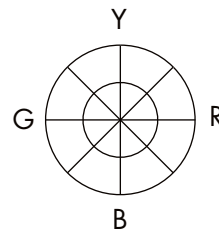
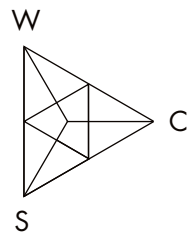
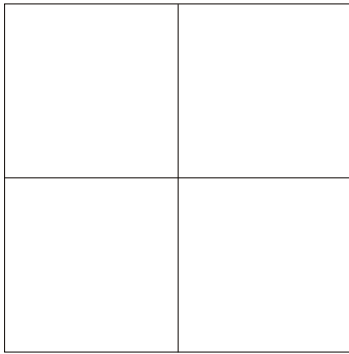

Hue

Arrange the colour samples in three groups differing in hue. In each group the colours should have the same hue - i.e. the relation between the two chromatic elementary attributes should be constant (in this case redness-blueness). Mount the samples in groups in the squares and indicate the hue with a line in the colour circle, radiating from the centre of the colour triangle.

Nuance Similarity 4.1

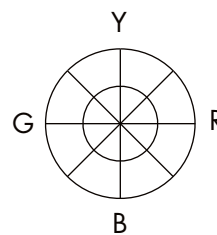
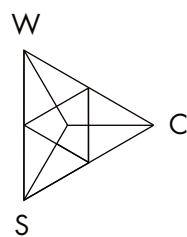
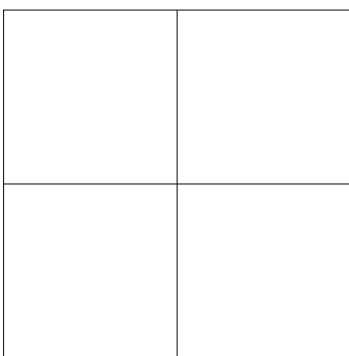
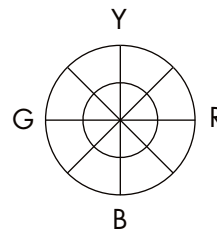
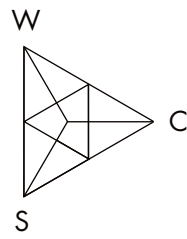
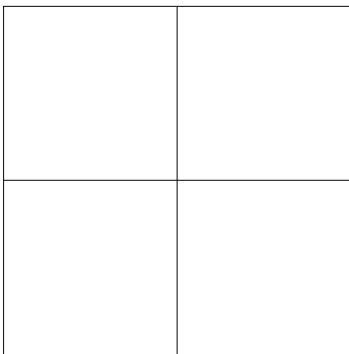
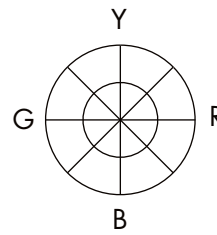
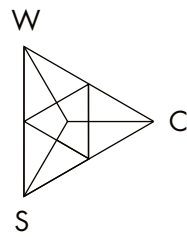
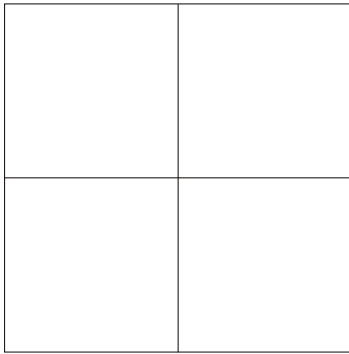

Nuance

Arrange the colour samples in three groups that differ in nuances. In each group the colours should have the same whiteness, blackness and chromaticness. In each group the nuances are therefore similar. This is illustrated by a dot in the colour triangle. Indicate the nuance in the three groups with a dot in the colour triangles and the different hues in the colour circles.

Blackness Similarity 4.2

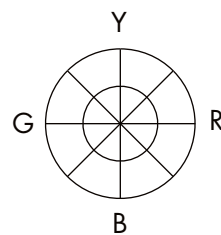
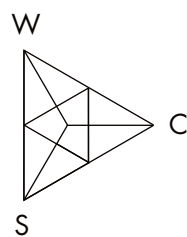
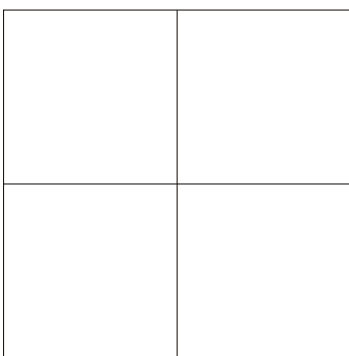
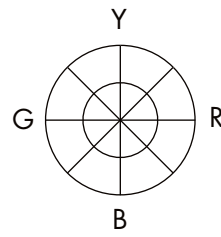
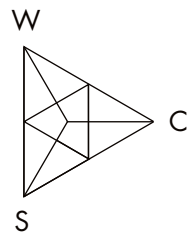
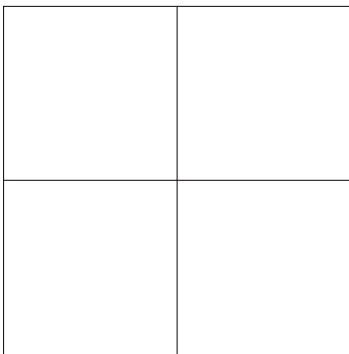
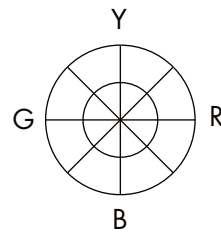
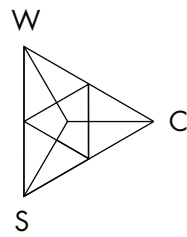
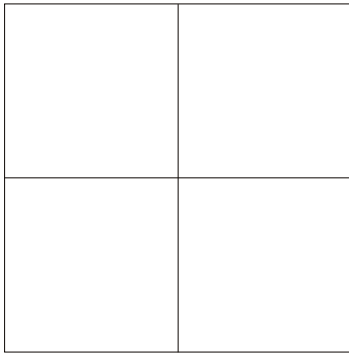

Blackness

Arrange the colour samples in three groups differing in degree of blackness (high, medium, low). In each group the colours should have similar blackness. Mount the samples in groups in the squares and indicate the degree of blackness with a line through each colour triangle.

Chromaticness Similarity 4.2

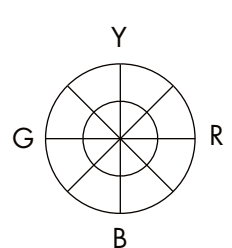
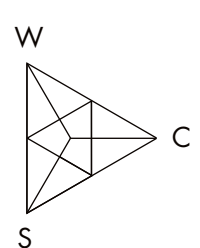
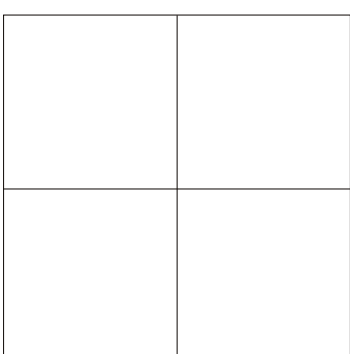
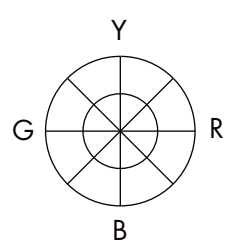
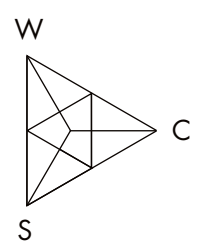
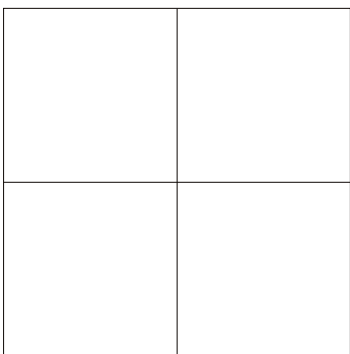
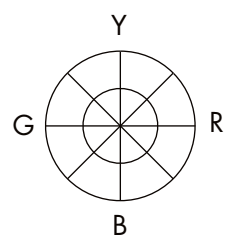
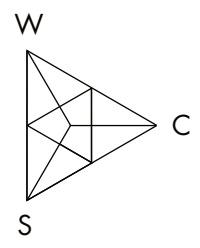
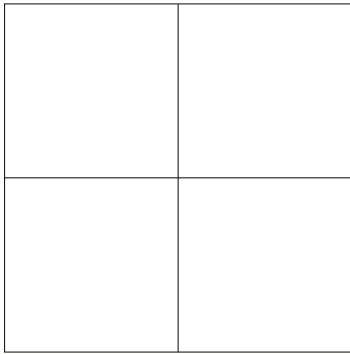

Chromaticness
 Arrange the colour samples in three groups differing in degree of chromaticness (high, medium, low). In each group the colours should have similar chromaticness. Mount the samples in groups in the squares and indicate the degree of chromaticness with a line through each colour triangle.

Whiteness Similarity 4.2

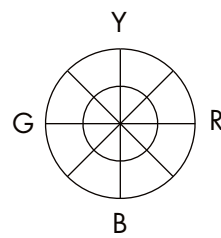
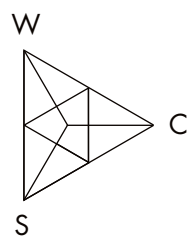
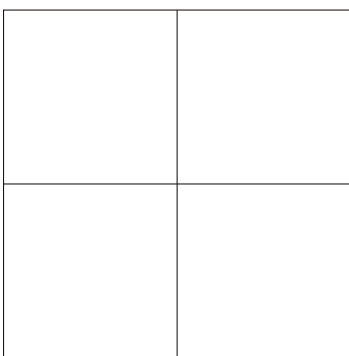
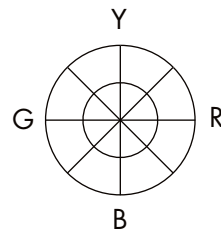
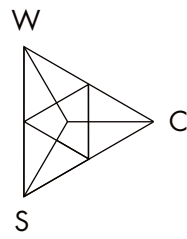
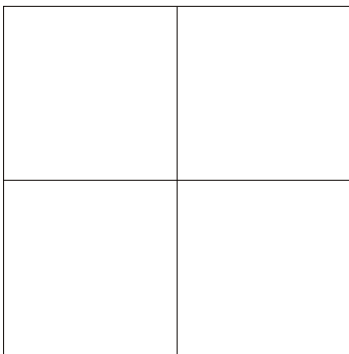
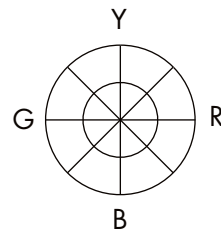
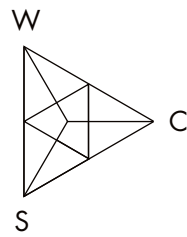
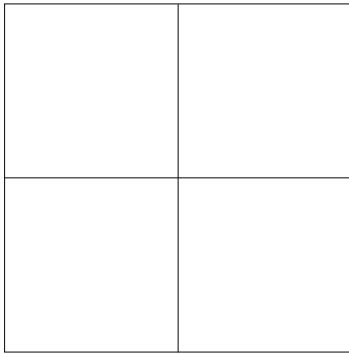

Whiteness

Arrange the colour samples in three groups differing in degree of whiteness (high, medium, low). In each group the colours should have similar whiteness. Mount the samples in groups in the squares and indicate the degree of whiteness with a line through each colour triangle.



Lightness Similarity 5.1

W
S

Pick out the eight achromatic colour samples and arrange them in a scale from white (W) to black (S). Then take one chromatic colour sample at a time and compare this colour with the scale from white to black. Where the borderline between the samples is minimally distinct, the chromatic colour sample has the same lightness as the grey sample. Mount the chromatic samples in horizontal columns out from the corresponding grey sample.

Simultaneous Contrast: Lightness 5.2

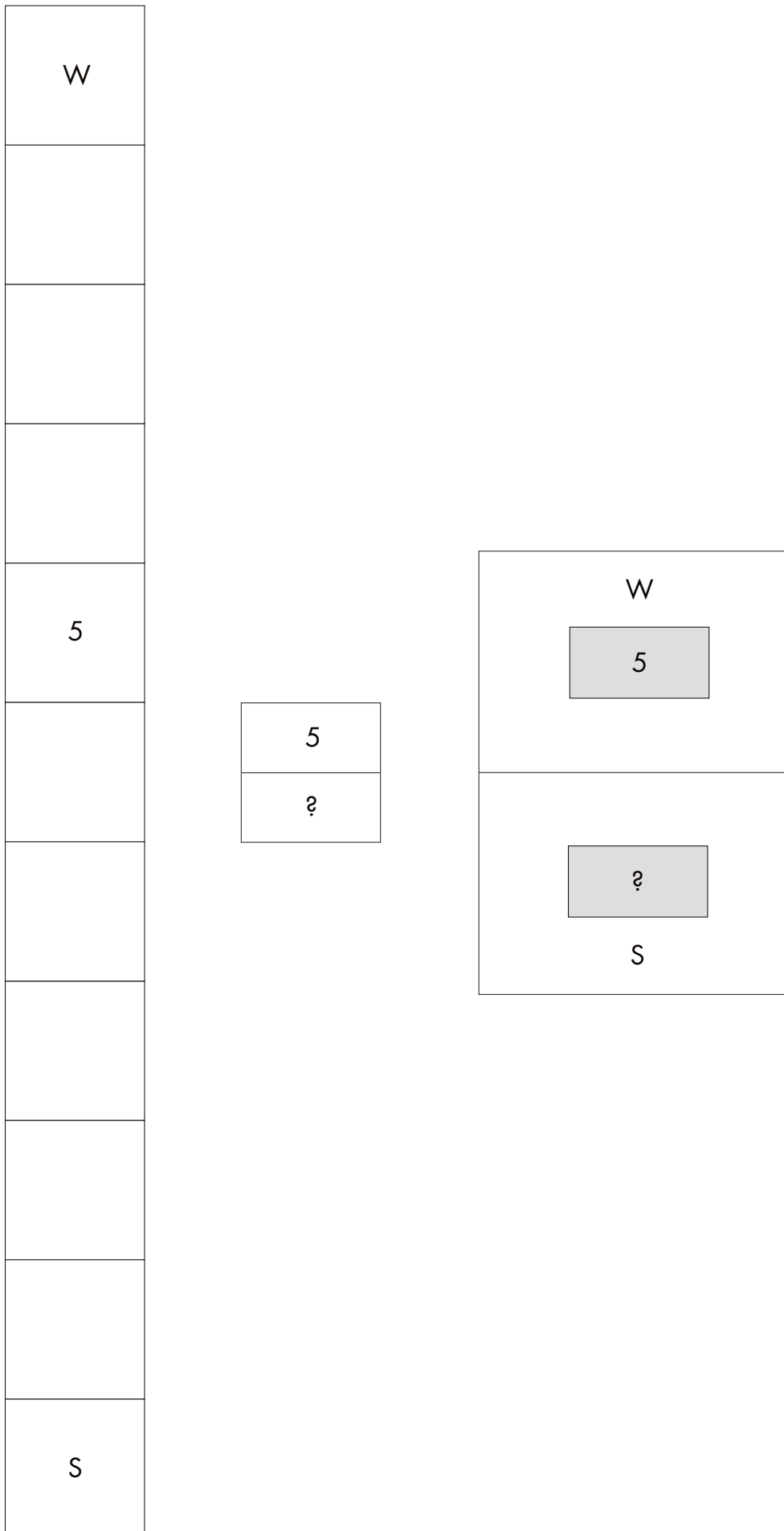

Mount the two large samples to the right as indicated. The smaller samples should be arranged from white to black in the scale to the left.

Put the sample number 5 in the centre of the large white sample. Then try to find another sample from the scale that, when put on the black background, has the same lightness as number 5. Cut the two samples in half and mount one of each on the large samples. The other halves should be mounted in the rectangular spaces to the left of the large samples (sample number 5 at the top).

Simultaneous contrast: hue, nuance 5.3



1. Hue

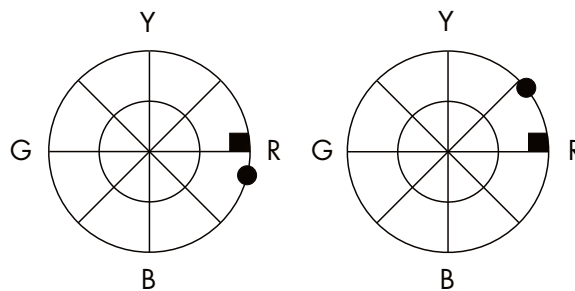
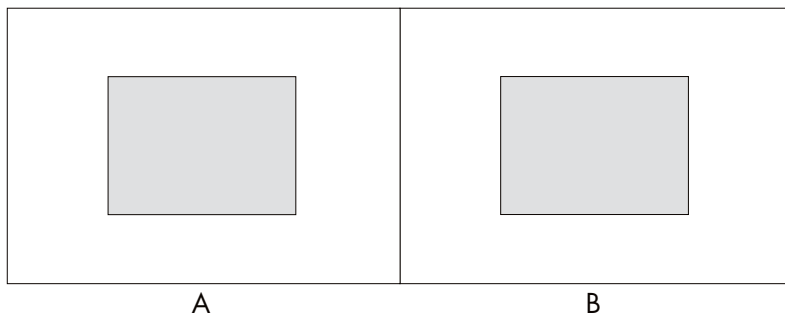

2. Whiteness

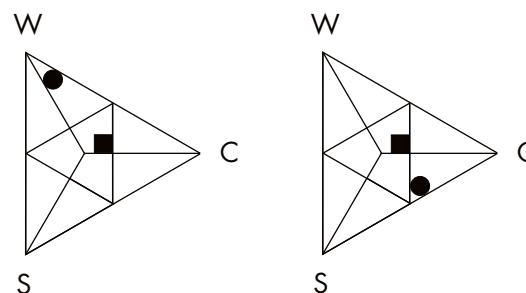
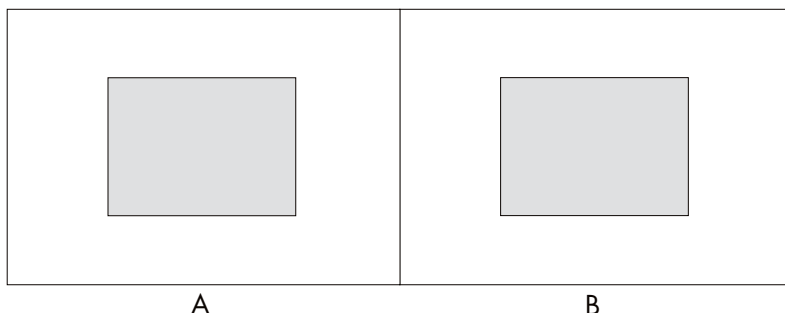

3. Blackness

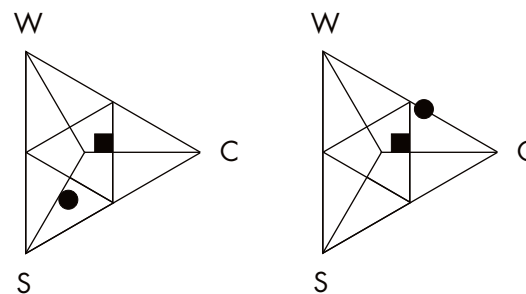
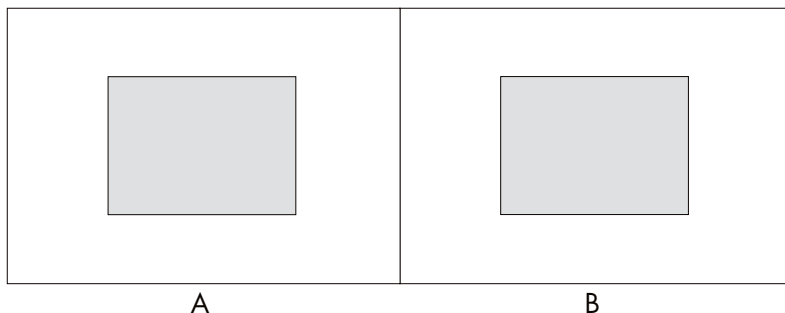

4. Chromaticness

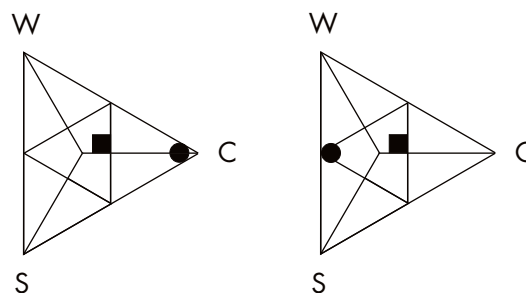
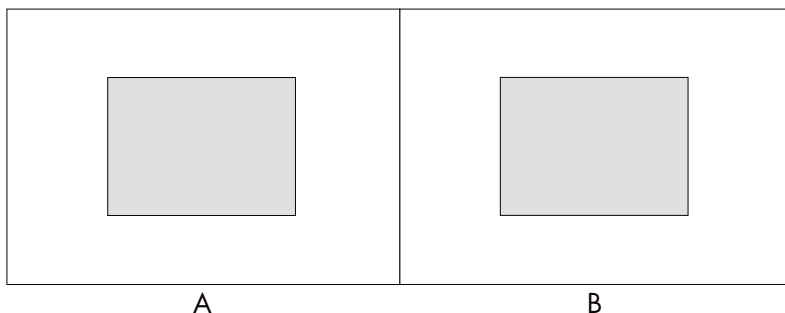

● = background ■ = middle

Find the two samples that have the same colour and cut them each in four equal parts. The other colour samples should be used as background for these smaller samples. Mount the most blueish colour sample in 1A and the most yellowish in 1B. Then mount a small sample on top of each of these. Indicate in the colour circle with a small

arrow how the hue of the smaller colour samples is changed by the influence of the background colour. Mount the most whitish colour sample in square 2A, the most blackish in 3A and the most chromatic in 4A. In the squares 2B, 3B and 4B you mount the colour samples that differ most from the one mounted in the squares 2A, 3A and

4A in whiteness, blackness and chromaticness. Mount a small colour sample on top of each of these. Indicate with a small arrow in the colour triangle, starting from the indication of the middle sample, how the nuances (whiteness, blackness and chromaticness) change by the influence of the background colour.